



## Assembly Instructions

**Thank you** for purchasing the Low Profile Adjustable Seat Slide by TACO Marine. Since 1959, we have taken great pride in offering the highest-quality products with excellent customer service. We stand behind our products 100 percent. Please visit our website [tacomarine.com](http://tacomarine.com) for more detailed information on a wide variety of products and to register your new accessory for warranty.

### WARNING

Always check below the surface that you are drilling into for electrical wires, tanks, hoses or other items that could be damaged by your drill bit or screws.

### Box Includes

- ONE (1) SEAT SLIDE HOUSING ASSEMBLY
- ONE (1) MOUNTING PLATE
- TWO (2) WASHERS
- TWO (2) FASTENERS

### Required, but not included

- EIGHT (8) 1/4" FLAT HEAD MACHINE SCREWS

### MAINTENANCE

The mounting plate and two rails are made with anodized aluminum. This creates a very hard protective seal on the surface of the aluminum to protect it as much as possible from pitting. When the anodized coating is broken and raw aluminum is exposed, corrosion will take place. Avoid damage from abrasive chemicals, knives, gaffs or impacts that can break the anodized coating. Always use a mild, non-abrasive soap and lots of fresh water when cleaning any aluminum product on your boat.

For more information on maintenance, visit [tacomarine.com](http://tacomarine.com) to view TACO Marine's Stainless Steel & Aluminum Care Guide.

### HANDY TIP

Install Seat Slide housing assembly to seat using the seat manufacture's recommended hardware.

## INSTALL INSTRUCTIONS

1. Un-package the Seat Slide and place on a stable surface.

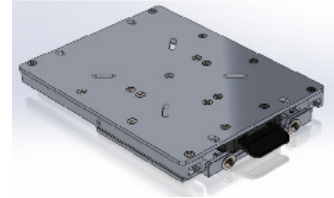

2. Attach the mounting clamp through the boat seat base using 1/4" countersunk bolts, washer and nuts.

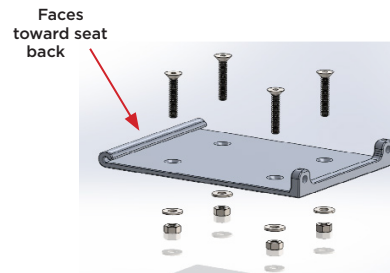

3. Align Seat Slide so the bottom slots are aligned with the holes in the bottom of the seat.

**NOTE: Ensure that the Seat Slide Activation Handle is facing toward the front of the seat.**

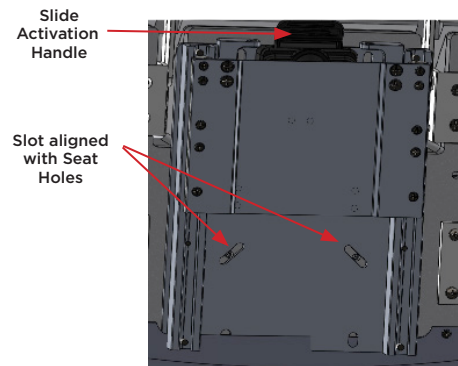

4. Attach the Seat Slide to the Seat with 1/4" bolts and washers, as shown.

**NOTE: Tighten these by hand snugly, as the next step will require exact alignment.**

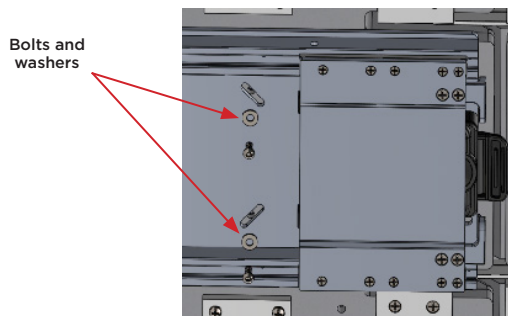

5. Activate the Seat Slide Handle and move the Slide Plate away from the activation handle.

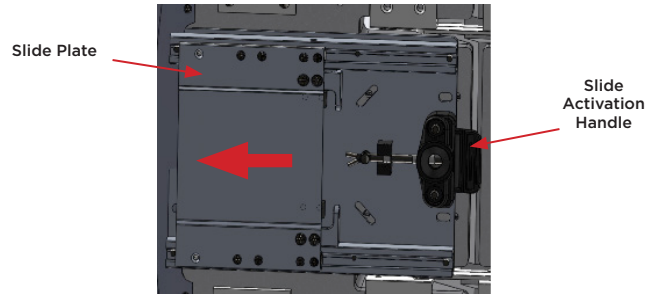

6. Align Seat Slide so the top slots are aligned with the holes in the bottom of the seat.

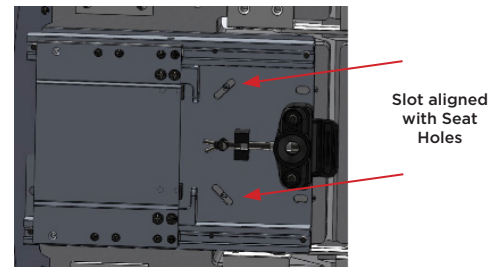

7. Attach the Seat Slide to the Seat with 1/4" bolts and washers, as shown. This is the same process as Step 6.

**NOTE: Tighten these down completely with an Allen wrench.**

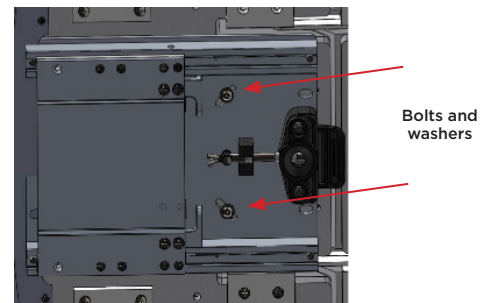

8. Activate the Seat Slide Handle and move the Slide Plate forward, as shown. Tighten the 1/4" bolts completely from Step 4.

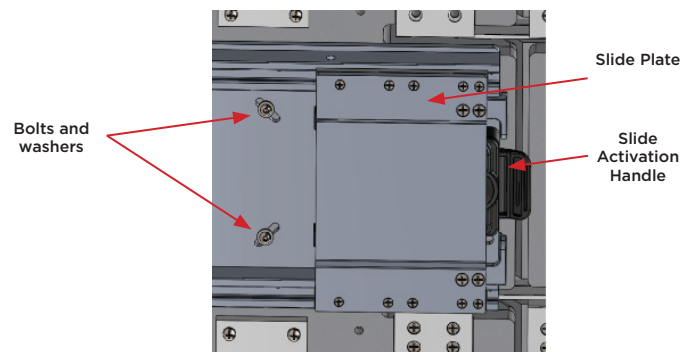

**Directions continued on page 6.**

12-1/4"  
10-5/8"

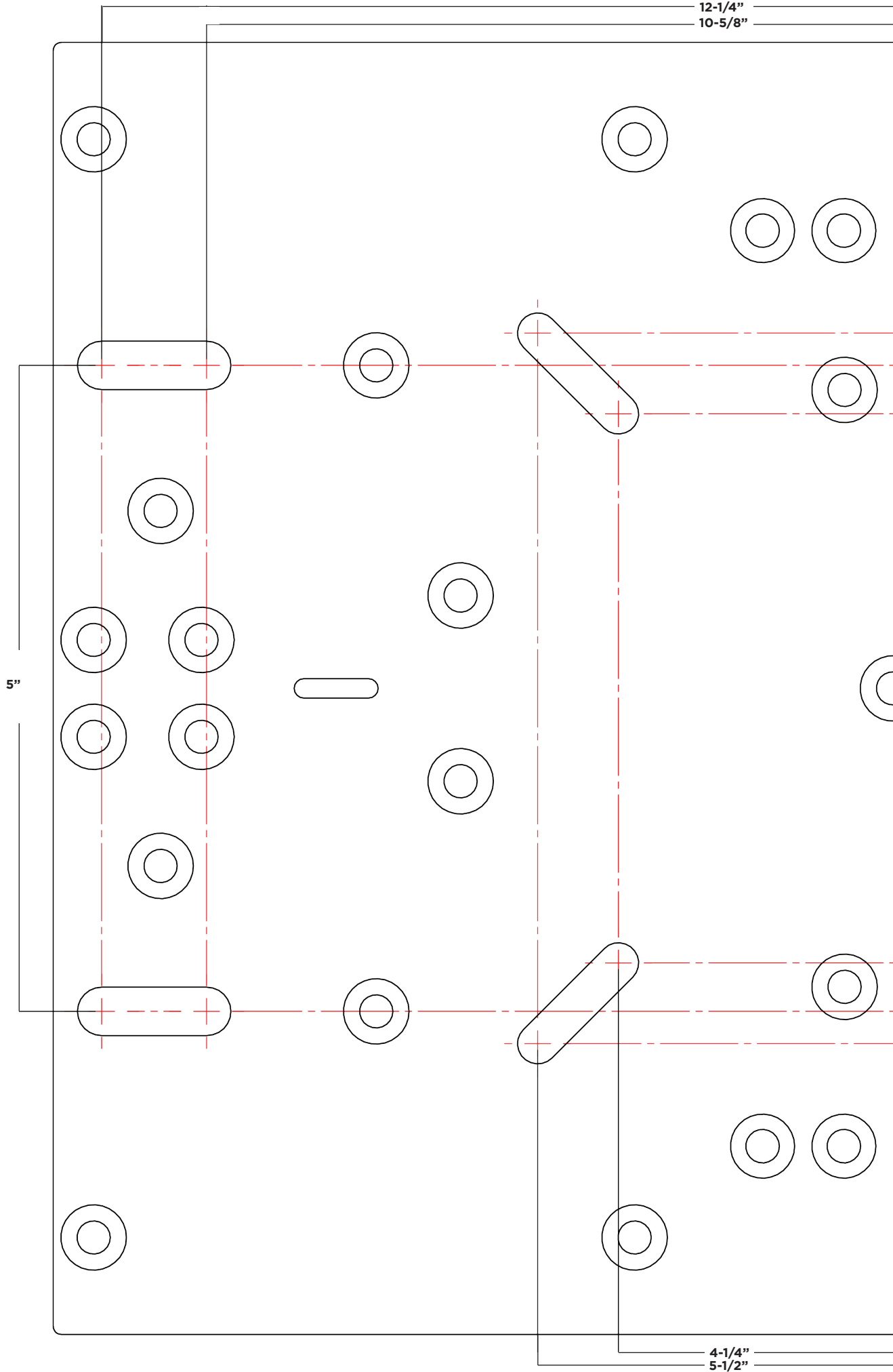

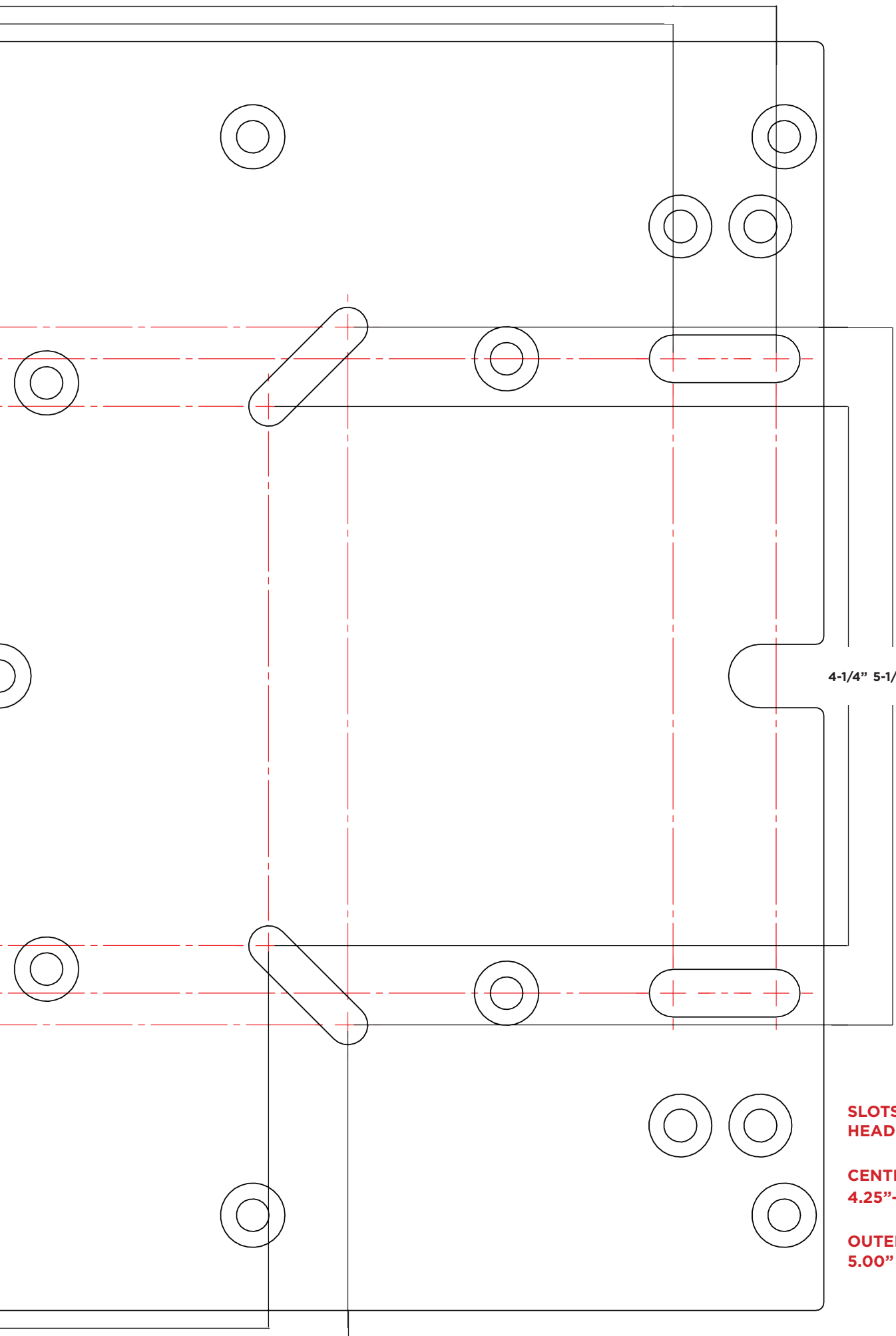

4-1/4" 5-1/2"

**SLOTS FOR 1/4-20 TRUSS  
HEAD FASTNERS**

**CENTER SLOTS :  
4.25"-5.5" X 4.25"-5.5"**

**OUTER VERTICAL SLOTS:  
5.00" X 10.63"-12.25"**

## INSTALL INSTRUCTIONS CONTINUED

9. **NOTE: For ease of installation, it is recommended that this step be done as a team.**

Lift the seat and position onto the Mounting Clamp, as shown. Ensure that the Seat Slide activation handle is oriented toward the front of the seat.

**NOTE: Mounting Clamp is shown un-installed for visual representation of mounting the Seat.**

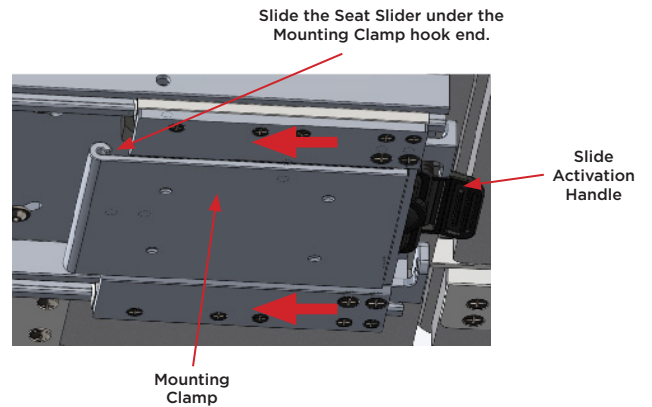

10. Mount the 1/4" bolts and washers to the assembly using an Allen wrench, as shown to the right.

**NOTE: Seat is not shown installed in the step.**

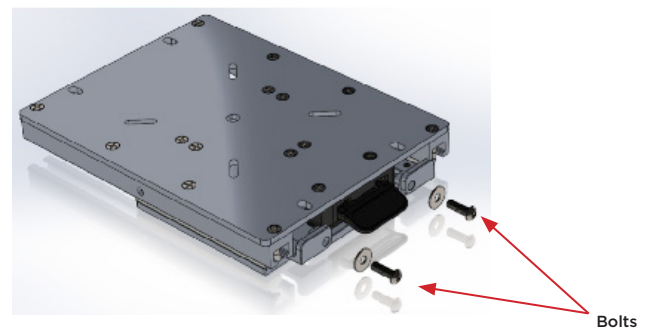

11. Ensure that the bolts from Step 10 are completely tightened.

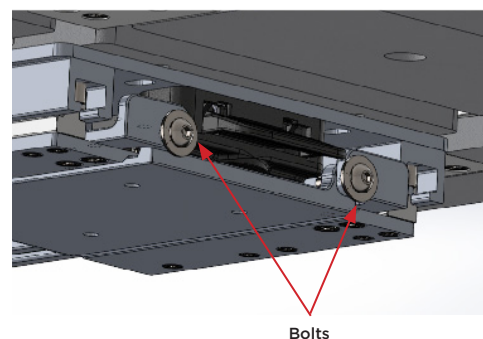

12. Operate the Seat Slide to ensure smooth

**BOTTOM PLATE DRILL TEMPLATE**

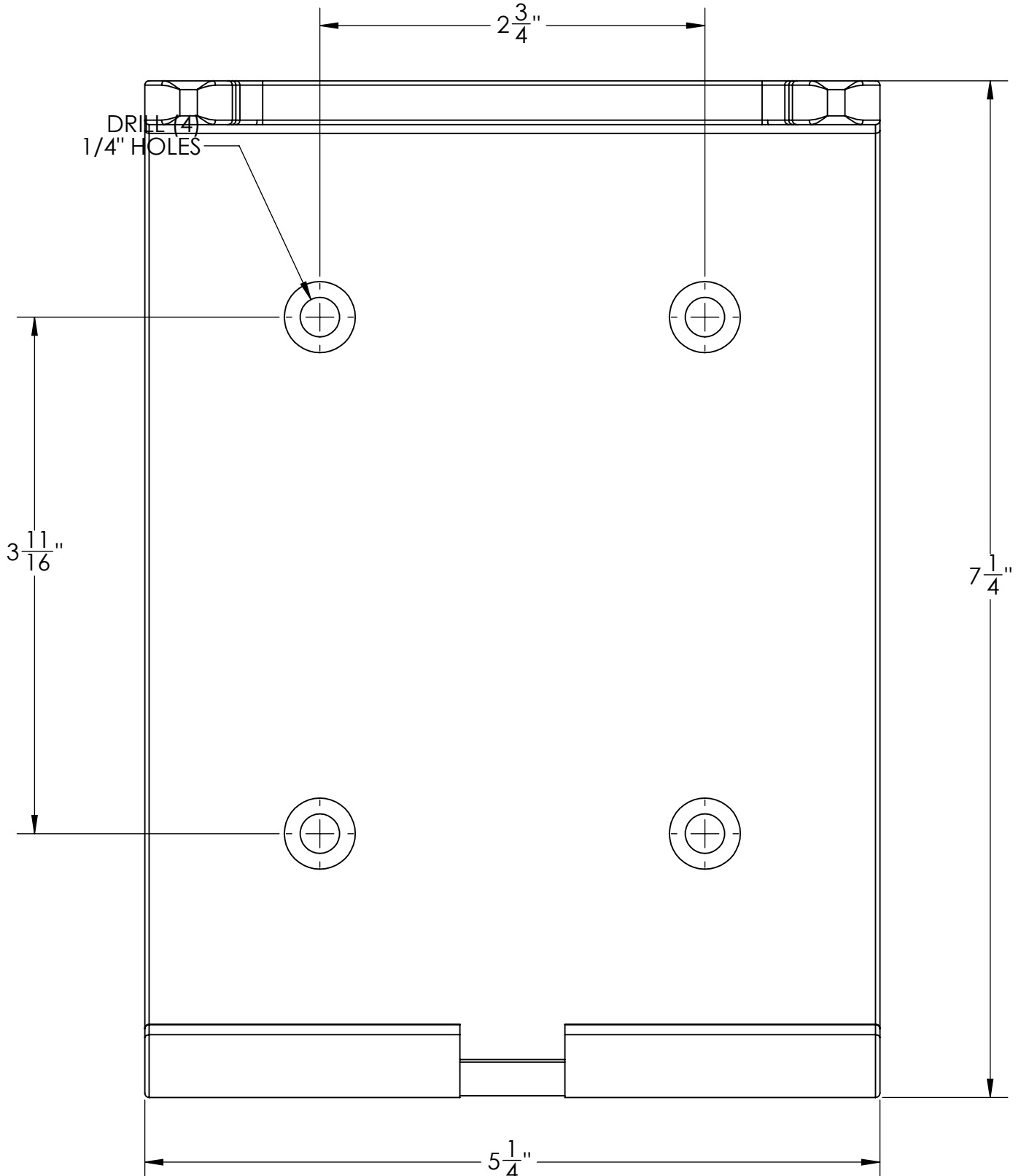

Please print at 100 percent for accurate sizing. Slight scaling may still occur. Therefore, before drilling, it is recommended that all template dimensions are measured for accuracy.

